

www.roll-packaging.com



INNOVATION FOR HEAVY ROLL LOGISTICS

Discover alternatives for roll handling, storage and transport



EXPERTS IN ROLL PACKAGING

MADE IN COMO. INNOVATIVE SOLUTIONS FOR INDUSTRIAL ROLL STORAGE

We are a young company, yet deeply rooted in technical excellence.

Founded in 2012 in the north of Milan, we have rapidly established ourselves as a strategic partner for industries that demand more than off-the-shelf solutions.

Our team consists of expert technicians who speak the language of production.

We understand the challenges faced by those who extrude film, print flexible packaging, manufacture paper, textile,...

We know that handling heavy reels requires resistance, safety, and a level of cleanliness that traditional wooden supports can no longer guarantee.

Beyond the Standard: We engineer custom solutions tailored to the specific requirements of each industry sector.

Protected Innovation: We hold a portfolio of proprietary, exclusive solutions backed by multiple international patents.

Multi-Material Approach: Plastics, paperboard, metal. We select the optimal technology — injection moulding, rotational moulding, carton — for each individual application requirement.

Lean Efficiency: A streamlined organizational structure designed to deliver the best performance-to-cost ratio.

Global Reach: We export over 70% of our production worldwide.

Safety & Hygiene Compliance: We replace nails and wood with advanced systems that comply with the highest occupational health and safety standards.

Siamo una realtà giovane, ma con radici profonde nell'eccellenza tecnica.

Nati nel 2012 a Nord di Milano, ci siamo rapidamente affermati come partner strategico per le industrie che non si accontentano di soluzioni standard.

Il nostro team è composto da tecnici esperti che parlano la lingua della produzione

Conosciamo le sfide di chi estrude film, stampa imballaggi flessibili, produce carta o tessuti...

Sappiamo che la movimentazione di bobine pesanti richiede resistenza, sicurezza e una pulizia che i supporti tradizionali in legno non possono più garantire.

Oltre lo Standard: Progettiamo su misura per i settori specifici dei nostri clienti.

Innovazione Protetta: Vantiamo un portafoglio di soluzioni esclusive e numerosi brevetti internazionali.

Approccio Multi-Materiale: Plastica, cartone, metallo. Scegliamo la tecnologia migliore (iniezione, rotazionale, cartotecnica,...) per ogni specifica esigenza.

Efficienza Lean: Struttura snella per garantire il miglior rapporto performance/prezzo.

Respiro Globale: Esportiamo oltre il 70% della nostra produzione in tutto il mondo.

Sicurezza e Igiene: Sostituiamo chiodi e legno con sistemi avanzati, conformi ai più alti standard di sicurezza sul lavoro.



14+ years
of experience



70%+
International Export



100+
solutions in catalog



20%
average annual growth

OUR HISTORY



ROLL PALLET 800x1200 for rack or shelves storage

RCV69



...best-priced roll pallet for racking...



* IS MADE UP OF THE PP 69 PALLET (EQUIPPED WITH METAL BARS) AND THE CV02 SADDLE

800 (l) x 1200 (w) - 275 (h) mm
31.5 (l) x 47.2 (w) - 10.8 (h) in

28 Kg/unit - 8 units (min order)
62 lb

1400 mm	1200 Kg	1	1000 Kg	2/4	3/5
---------	---------	---	---------	-----	-----



LO02

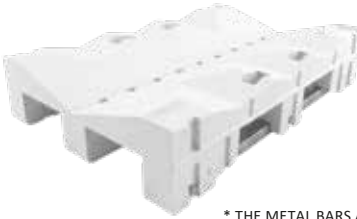

...maximum strength pallet for rack systems with steel bars...



* THE METAL BARS ARE THE SKIDS

800 (l) x 1200 (w) - 240 (h) mm
31.5 (l) x 47.2 (w) - 9.4 (h) in

19 Kg/unit - 9 units (min order)
42 lb

1200 mm	1800 Kg	1-3	1500 Kg	2/4	5/5
---------	---------	-----	---------	-----	-----



RP01



...the classic roll pallet with robust support wedges...



* WITHOUT METAL BARS

800 (l) x 1200 (w) - 242 (h) mm
31.5 (l) x 47.2 (w) - 9.5 (h) in

28 Kg/unit - 11 units (min order)
62 lb

1200 mm	1200 Kg	1	600	2/4	3/5
---------	---------	---	-----	-----	-----



RCV49



...favored by printers for clean, efficient and reusability...



* IS MADE UP OF THE PP 69 PALLET (EQUIPPED WITH METAL BARS) AND THE CV01 SADDLE

800 (l) x 1200 (w) - 190 (h) mm
31.5 (l) x 47.2 (w) - 7.5 (h) in

22.5 Kg/unit - 11 units (min order)
50 lb

1100 mm	1200 Kg	1-2	1000	2/4	4/5
---------	---------	-----	------	-----	-----



RCV49b



...RCV49 variant for single roll with flat, step-free wedge...



* IS MADE UP OF THE PP 69 PALLET (EQUIPPED WITH METAL BARS) AND THE CV01b SADDLE

800 (l) x 1200 (w) - 190 (h) mm
31.5 (l) x 47.2 (w) - 7.5 (h) in

22.5 Kg/unit - 11 units (min order)
50 lb

1300 mm	1200 Kg	1	1000	2/4	4/5
---------	---------	---	------	-----	-----



RC69-1



...Combo saddle design for stable handling and reduced surface stress...

* IS MADE UP OF THE PP 69 PALLET (EQUIPPED WITH METAL BARS) AND THE CO01-H SADDLE (POLYUREA-COATED EXPANDED POLYSTYRENE SADDLES)

800 (l) x 1200 (w) - 270 (h) mm
31.5 (l) x 47.2 (w) - 10.6 (h) in

19 Kg/unit - 8 units (min order)
42 lb

1100 mm	1200 Kg	1	800	2/4	3/5
---------	---------	---	-----	-----	-----



RC69-3L



...engineered combo solution for multi-cylinder storage...

* IS MADE UP OF THE PP 69 PALLET (EQUIPPED WITH METAL BARS) AND THE CO03-L SADDLE (POLYUREA-COATED EXPANDED POLYSTYRENE SADDLES)

800 (l) x 1200 (w) - 270 (h) mm
31.5 (l) x 47.2 (w) - 10.6 (h) in

19 Kg/unit - 8 units (min order)
42 lb

1100 mm	1200 Kg	3	800	2/4	3/5
---------	---------	---	-----	-----	-----



RCV43



...RCV49 concept on H1 pallet with closed runners for hygiene...

* IS MADE UP OF THE PP H1 PALLET (WITH CLOSED SKIDS) AND THE CV01 SADDLE

800 (l) x 1200 (w) - 242 (h) mm
31.5 (l) x 47.2 (w) - 9.5 (h) in

28 Kg/unit - 11 units (min order)
62 lb

1100 mm	1200 Kg	1-2	800	2/4	5/5
---------	---------	-----	-----	-----	-----



ROLL PALLET 800x1200 - 4 WAYS

for floor handling

LO01

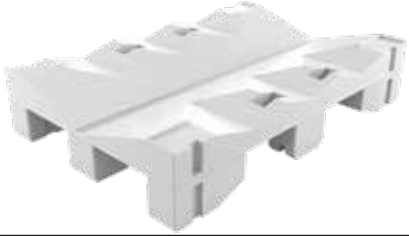

...High-performance pallet for 1 or 3 rolls with hygienic design...

800 (l) x 1200 (w) - 240 (h) mm
31.5 (l) x 47.2 (w) - 9.4 (h) in
15 Kg/unit - 9 units (min order)
33 lb

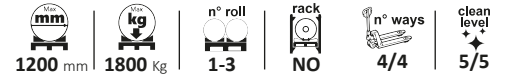

RCV08



...4-way pallet with CV01 cradle ensuring hygienic handling

800 (l) x 1200 (w) - 190 (h) mm
31.5 (l) x 47.2 (w) - 7.5 (h) in
26 Kg/unit - 11 units (min order)
57 lb



* IS MADE UP OF THE PP08 PALLET (4 WAYS) AND THE CV01 SADDLE

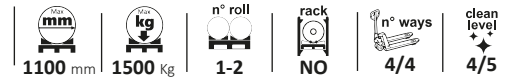

RCV28



...4-way entry pallet with competitive price advantage

800 (l) x 1200 (w) - 270 (h) mm
31.5 (l) x 47.2 (w) - 10.6 (h) in
31 Kg/unit - 8 units (min order)
68 lb



* IS MADE UP OF THE PP08 PALLET (4 WAYS) AND THE CV02 SADDLE

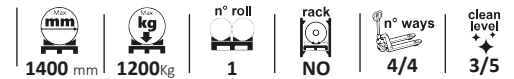

RCV08b

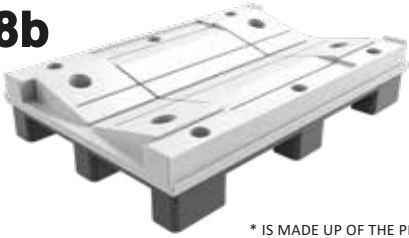

...4-way entry pallet with smooth, step-free wedge saddle..

800 (l) x 1200 (w) - 190 (h) mm
31.5 (l) x 47.2 (w) - 7.5 (h) in
26 Kg/unit - 11 units (min order)
57 lb



* IS MADE UP OF THE PP08 PALLET (4 WAYS) AND THE CV01b SADDLE

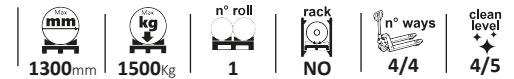

ROLL PALLET XS

for floor handling

RM01

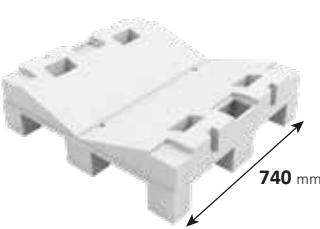

...high-strength 4-way roll pallet ideal for clean applications...

740 (l) x 800 (w) - 220 (h) mm
29.1 (l) x 31.5 (w) - 8.7 (h) in
11 Kg/unit - 10 units (min order)
24 lb

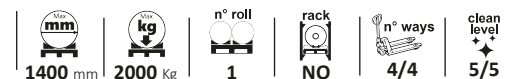

RP02



...heavy-duty 4-way pallet built for extreme durability...

670 (l) x 1000 (w) - 180 (h) mm
26.4 (l) x 39.4 (w) - 7.1 (h) in
19.5 Kg/unit - 18 units (min order)
62 lb

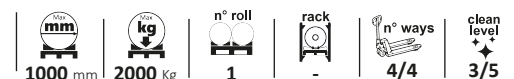

RCH2-L

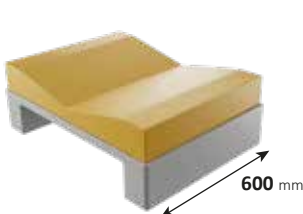

...2-way entry pallet for compact applications...

800 (l) x 600 (w) - 280 (h) mm
31.5 (l) x 23.6 (w) - 11 (h) in
10.7 Kg/unit - 14 units (min order)
24 lb

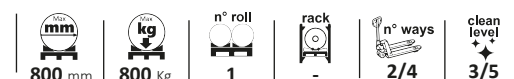

ROLL PALLET XL

for floor handling

SO01

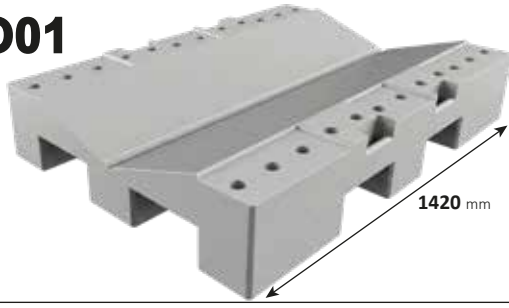

...price-efficient solution in the extra-large pallet segment...

980 (l) x 1420 (w) - 260 (h) mm

38.6 (l) x 55.9 (w) - 10.2 (h) in

22.5 Kg/unit - 9 units (min order)

50 lb

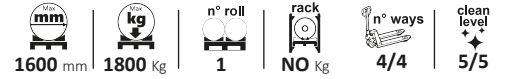

SO02

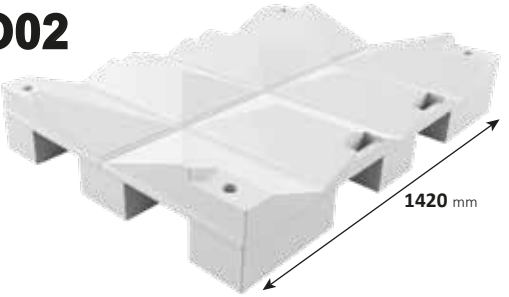

...like SO02, designed for 1 to 3 roll configurations...

980 (l) x 1420 (w) - 260 (h) mm

38.6 (l) x 55.9 (w) - 10.2 (h) in

18.6 Kg/unit - 9 units (min order)

41 lb

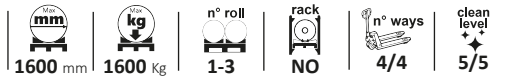

RM02

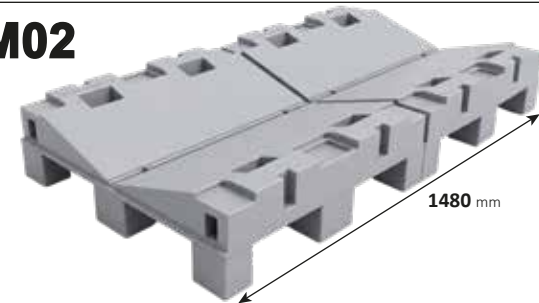

...ultra-strong XL roll pallet with 4 metal reinforcement bars...

800 (l) x 1480 (w) - 220 (h) mm

31.5 (l) x 58.3 (w) - 8.7 (h) in

34 Kg/unit - 10 units (min order)

75 lb

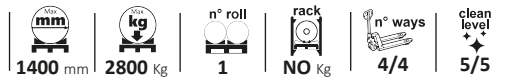

RM03

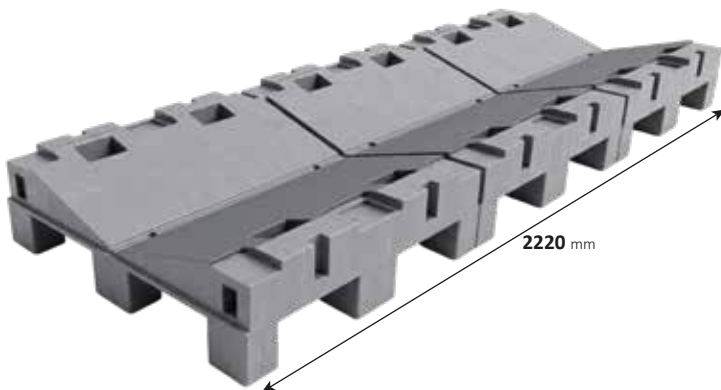

...long-format pallet from RM01 with 3 modules and steel bars...

800 (l) x 2220 (w) - 220 (h) mm

31.5 (l) x 87.4 (w) - 8.7 (h) in

52 Kg/unit - 10 units (min order)

115 lb

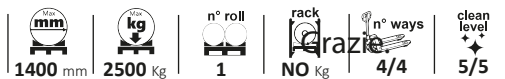

LOAD TYPE CAPACITY

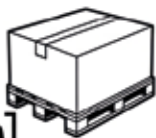

STATIC LOAD
(Uniform Weight)
Maximum stationary weight capacity on a flat surface.



DYNAMIC LOAD
(Uniform Weight)
Maximum weight capacity during forklift or pallet jack handling.

PALLET STORAGE SCENARIOS

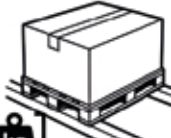

RACKING LOAD
(Uniform Weight)
Maximum weight capacity in drive-in or selective racking systems.

SPECIALIZED LOAD: CYLINDRICAL ROLLS



FLOOR STORAGE
(Concentrated Load)

Roll pallet resting directly on ground surface.

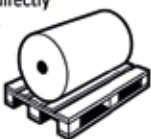

SHELF STORAGE
(Concentrated Load)

Roll pallet supported by solid flat shelving units.



RACK STORAGE
(Concentrated Load)

Roll pallet supported exclusively by racking beams.

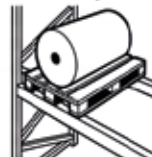

CRITICAL TECHNICAL WARNING

ROLL PALLET RESISTANCE VS. UNIFORM LOADS

The structural resistance of a pallet carrying cylindrical loads (rolls) differs significantly from that of uniformly distributed loads.

Because the load is not evenly spread, deformation forces are highly concentrated within a restricted contact area on the pallet surface.

ACTION REQUIRED: A specific load resistance test is mandatory to determine safe operational capacities for roll handling and storage.

TRANSFORMER/1 *(fixed wedge design)*

system to transform standard pallets into roll pallet

CV01



...versatile, **hygienic pallet conversion for 1 or 2 rolls...**

818 (l) x 1218 (w) - 70 (h) mm
32.2 (l) x 48 (w) - 2.8 (h) in

7 Kg/unit - 30 units (min order)
15 lb

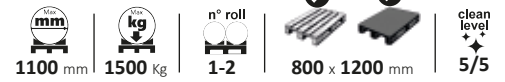

* Universal fit for 800x1200 plastic and wooden pallets

CV01b

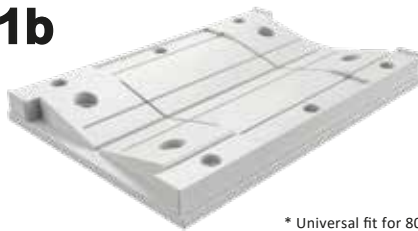

...CV01-style for **large rolls with step-free wedge for easy loading...**

818 (l) x 1218 (w) - 70 (h) mm
32.2 (l) x 48 (w) - 2.8 (h) in

7 Kg/unit - 30 units (min order)
15 lb

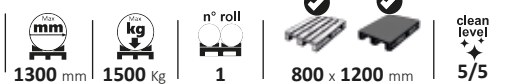

* Universal fit for 800x1200 plastic and wooden pallets

CV02



...**cost-efficient saddle with wide V-shape for large diameter rolls...**

810 (l) x 1210 (w) - 175 (h) mm
31.9 (l) x 47.6 (w) - 6.9 (h) in

11 Kg/unit - 10 units (min order)
24 lb

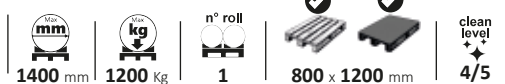

* Universal fit for 800x1200 plastic and wooden pallets

CO01-w



...converts wood pallets with durable **combo saddle and gentle contact...**

780 (l) x 1180 (w) - 120 (h) mm
30.7 (l) x 46.5 (w) - 4.7 (h) in

3.5 Kg/unit - 18 units (min order)
8 lb

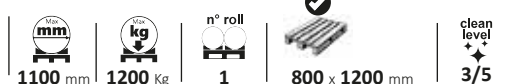

* Adapted to Euro pallets with customizable form options

CO02-w



...CO01-W design adapted for **1 or 2 roll handling...**

780 (l) x 1180 (w) - 120 (h) mm
30.7 (l) x 46.5 (w) - 4.7 (h) in

3.5 Kg/unit - 18 units (min order)
8 lb



* Adapted to Euro pallets with customizable form options

TRANSFORMER/2 *(position-adjustable wedges)*

system to transform standard pallets into roll pallet

SB01

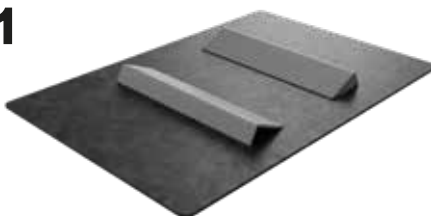

...smart kit for any pallet with **adjustable wedges and easy loading...**

800 (l) x 1200 (w) - 60 (h) mm
31.5 (l) x 47.2 (w) - 2.4 (h) in

10.2 Kg/unit - 20 units (min order)
22 lb



* Kit with 2 wedges 570 mm (KU04-570) and 800x1200 rubber mat

SB02

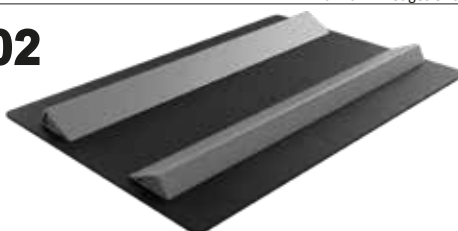

...SB01 concept with **longer support wedges...**

800 (l) x 1200 (w) - 60 (h) mm
31.5 (l) x 47.2 (w) - 2.4 (h) in

12.6 Kg/unit - 20 units (min order)
22 lb



* Kit with 2 wedges 1143 mm (KU04-1143) and 800x1200 rubber mat

ROLL CHOCKS/WEDGES

for safe roll blocking and handling

KU10



KU10C

colored KU10 for improved visual management



...Plastic wedges at **competitive cost** for one-way use...



FRICITION TEETH

* Bottom teeth ensure grip on soft surfaces like cardboard

150 (l) x 260 (w) - 50 (h) mm

5.9 (l) x 10.2 (w) - 2 (h) in

0.23 Kg/unit - 160 units (min order)

0.5 lb



KU10-2S

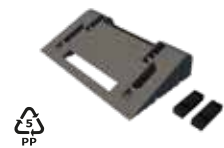

KU10C-2S

colored KU10-2S for improved visual management

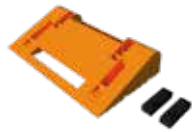

...competitive solution for roll securing **on plastic pallets**...



RUBBER PADS

* Wedge supplied with two rubber pads, ready for assembly

150 (l) x 260 (w) - 50 (h) mm

5.9 (l) x 10.2 (w) - 2 (h) in

0.23 Kg/unit - 160 units (min order)

0.5 lb



KU10ST

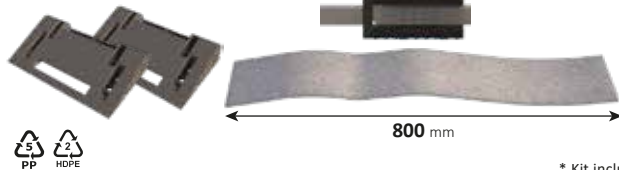

...patented **nail-free solution** to secure rolls **on any pallet**...



* Kit includes 2 wedges KU10 and 800 mm PE foam strip

150 (l) x 260 (w) - 50 (h) mm (X2)

5.9 (l) x 10.2 (w) - 2 (h) in (X2)

0.23 Kg/unit - 160 units (min order)

1 lb



KU04-570

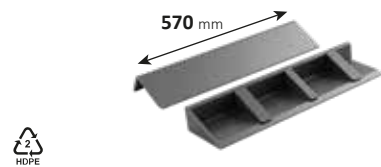

...reusable 570 mm PE wedge for efficient roll fixation on pallets...

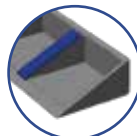

RUBBER PADS

* Wedges with rubber pads perform best on plastic or rubber mats

150 (l) x 570 (w) - 50 (h) mm

5.9 (l) x 22.4 (w) - 2 (h) in

1.1 Kg/unit - 20 units (min order)

2.4 lb



KU04-1143



...like KU04-570, but with **longer 1143 mm length**...

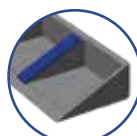

RUBBER PADS

* Wedges with rubber pads perform best on plastic or rubber mats

150 (l) x 1143 (w) - 50 (h) mm

5.9 (l) x 45 (w) - 2 (h) in

2.3 Kg/unit - 20 units (min order)

5.1 lb



PLASTIC PALLET

plastic pallet used as base for roll pallet

PP08 4-way entry and 9 feet

800 (l) x 1200 (w) - 140 (h) mm - 19 Kg/unit



1500 Kg

n° ways
4/4

PP69 reinforced with 3 metal bars

800 (l) x 1200 (w) - 155 (h) mm - 16 Kg/unit



1500 Kg

1200 Kg

PPH1 with closed runners

800 (l) x 1200 (w) - 160 (h) mm - 19 Kg/unit



1500 Kg

clean level
5/5

ROLL STICKO PAPER universal interlayers for multi-level stacked roll

PCU-80

780 (l) x 80 (w) - 100 (h) mm
30.7 (l) x 3.1 (w) - 3.9 (h) in



1) PCU-80 can also be used as a base. The angle adjusts automatically.

2) Use 2 x PCU-80, adjusting spacing based on roll number and diameter.

3) Build the pack step by step. PCU-80 boards support the load while providing a cushioned contact like cardboard for the roll.



ROLL STICKO PAPER preformed interlayers for multi-level stacked roll

2x 3x 4x 5x 6x

PC02-580

1160 (l) x 90 (w) - 140 (h) mm
45.7 (l) x 3.5 (w) - 5.5 (h) in



PC02-580B
BASE
70 units/pack (min order)



PC02-580I
INTERLAYER
70 units/pack (min order)



580				
560				
mm				

PC02-500

1000 (l) x 90 (w) - 140 (h) mm
39.4 (l) x 3.5 (w) - 5.5 (h) in

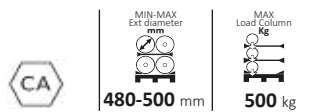

PC02-500B
BASE
80 units/pack (min order)



PC02-500I
INTERLAYER
80 units/pack (min order)



500				
480				
mm				

PC02-400

800 (l) x 90 (w) - 140 (h) mm
31.5 (l) x 3.5 (w) - 5.5 (h) in



















































PC02-400B
BASE
70 units/pack (min order)



PC02-400I
INTERLAYER
70 units/pack (min order)



400				
380				
mm				

				2x	3x	4x	5x	6x
PC03-400 1200 (l) x 90 (w) - 140 (h) mm 47.2 (l) x 3.5 (w) - 5.5 (h) in   380-400 mm  500 kg		PC03-400B BASE 70 units/pack (min order)	PC03-400I INTERLAYER 70 units/pack (min order)		400 380 mm			
								
PC03-300 950 (l) x 85 (w) - 90 (h) mm 37.4 (l) x 3.3 (w) - 3.5 (h) in   300-316 mm  400 kg		PC03-300B BASE 220 units/pack (min order)	PC03-300I INTERLAYER 120 units/pack (min order)		316 300 mm			
								
PC04-285 1200 (l) x 85 (w) - 90 (h) mm 47.2 (l) x 3.3 (w) - 3.5 (h) in   285-300 mm  400 kg		PC04-285B BASE 220 units/pack (min order)	PC04-285I INTERLAYER 130 units/pack (min order)			300 285 mm		
								
PC04-265 1120 (l) x 90 (w) - 90 (h) mm 44.1 (l) x 3.5 (w) - 3.5 (h) in   265-280 mm  400 kg		PC04-265B BASE 220 units/pack (min order)	PC04-265I INTERLAYER 130 units/pack (min order)			280 265 mm		
								
PC04-250 1060 (l) x 90 (w) - 80 (h) mm 41.7 (l) x 3.5 (w) - 3.1 (h) in   250-265 mm  300 kg		PC04-250B BASE 220 units/pack (min order)	PC04-250I INTERLAYER 130 units/pack (min order)			265 250 mm		
								
PC04-230 980 (l) x 90 (w) - 80 (h) mm 38.6 (l) x 3.5 (w) - 3.1 (h) in   230-245 mm  300 kg		PC04-230B BASE 220 units/pack (min order)	PC04-230I INTERLAYER 130 units/pack (min order)			245 230 mm		
								
PC05-200 1080 (l) x 90 (w) - 80 (h) mm 42.5 (l) x 3.5 (w) - 3.1 (h) in   200-215 mm  300 kg		PC05-200B BASE 220 units/pack (min order)	PC05-200I INTERLAYER 130 units/pack (min order)				215 200 mm	
								
PC06-160 1050 (l) x 90 (w) - 80 (h) mm 41.3 (l) x 3.5 (w) - 3.1 (h) in   160-175 mm  300 kg		PC06-160B BASE 220 units/pack (min order)	PC06-160I INTERLAYER 130 units/pack (min order)					175 160 mm
								

ROLL FLANGES

plastic pad for suspended packaging

FL01

330 (l) x 330 (w) - 30 (h) mm
13 (l) x 13 (w) - 1.2 (h) in



330 mm

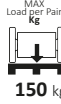

150 kg



FL01-76

PLUG 3"
270 units/pack
(min order)



FL01-152

PLUG 6"
270 units/pack
(min order)



FL08

400 (l) x 400 (w) - 35 (h) mm
15.7 (l) x 15.7 (w) - 1.4 (h) in



380 mm



150 kg



FL08-76

PLUG 3"
210 units/pack
(min order)



FL08-152

PLUG 6"
210 units/pack
(min order)



FL02

510 (l) x 500 (w) - 40 (h) mm
20.1 (l) x 19.7 (w) - 1.6 (h) in

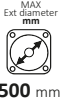

500 mm

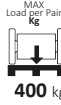

400 kg



FL02-76

PLUG 3"
100 units/pack
(min order)



FL02-152

PLUG 6"
100 units/pack
(min order)



FL03

600 (l) x 580 (w) - 40 (h) mm
23.6 (l) x 22.8 (w) - 1.6 (h) in

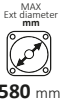

580 mm

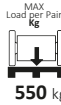

550 kg



FL03-76

PLUG 3"
100 units/pack
(min order)



FL03-152

PLUG 6"
100 units/pack
(min order)



FL04

620 (l) x 600 (w) - 40 (h) mm
24.4 (l) x 23.6 (w) - 1.6 (h) in

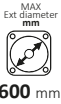

600 mm

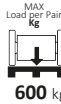

600 kg



FL04-152

PLUG 6"
100 units/pack
(min order)



FL05

700 (l) x 700 (w) - 50 (h) mm
27.6 (l) x 27.6 (w) - 2 (h) in

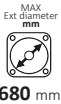

680 mm

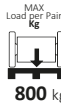

800 kg



FL05-152

PLUG 6"
50 units/pack
(min order)



FL06

840 (l) x 800 (w) - 60 (h) mm
33.1 (l) x 31.5 (w) - 2.4 (h) in

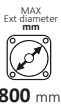

800 mm

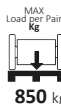

850 kg



FL06-152

PLUG 6"
25 units/pack
(min order)



FL06S-152

NOPLUG - HOLE 6"
26 units/pack
(min order)

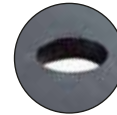

FL07

1040 (l) x 1000 (w) - 60 (h) mm
40.9 (l) x 39.4 (w) - 2.4 (h) in



1000 mm

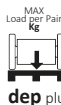

dep plug



FL07S-152

NOPLUG - HOLE 6"
30 units/pack
(min order)



ROLL PLUGS

plastic end caps supporting flanges

PL01

76 (diam) x 90 (length) mm
3 (diam) x 3.5 (length) in



2304 units/pack
(min order)

PL07

152 (diam) x 165 (length) mm
6 (diam) x 6.5 (length) in



288 units/pack
(min order)

ROLL PADS

light flanges for protecting rolls in carton boxes

FL51

220 (l) x 220 (w) - 23 (h) mm
8.7 (l) x 8.7 (w) - 0.9 (h) in

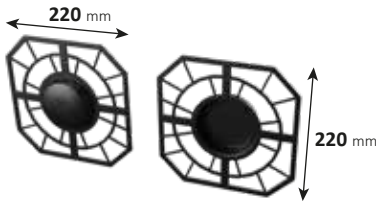

220 mm

FL051-76

PLUG 3"
2240 units/pack
(min order)

FL51-110

PLUG 4.3"
2060 units/pack
(min order)

ROLL HANGO

Foldable metal stillages for suspended storage

HA160-75

1600 (l) x 750 (w) - 1100 (h) mm
63 (l) x 29.5 (w) - 43.3 (h) in



* HABA-160 reinforced metal bar, 1600 mm, for this item

107 Kg/unit - 6 units (min order)
235 lb



HA160-110

1600 (l) x 1100 (w) - 1100 (h) mm
63 (l) x 43.3 (w) - 43.3 (h) in



* HABA-160 reinforced metal bar, 1600 mm, for this item

107 Kg/unit - 6 units (min order)
235 lb



HA210-75

2100 (l) x 750 (w) - 1100 (h) mm
82.7 (l) x 29.5 (w) - 43.3 (h) in



* HABA-210 reinforced metal bar, 2100 mm, for this item

112 Kg/unit - 6 units (min order)
246 lb



HA210-110

2100 (l) x 1100 (w) - 1100 (h) mm
82.7 (l) x 43.3 (w) - 43.3 (h) in



* HABA-210 reinforced metal bar, 2100 mm, for this item

112 Kg/unit - 6 units (min order)
246 lb



ROLL RECYCLO

machine for roll end separation and cores reuse

Efficient Recyclo machine for core reuse and material sorting...



1

EASY LOADING

- MAX ROLL DIAMETER: 600 mm
- MAX ROLL LENGTH: 1500 mm
- MAX ROLL WEIGHT: 150 kg

Efficiently handle large and heavy rolls.

2

FAST SET-UP

- USER SETTINGS** (Only 2 Parameters): Core Wall (mm) and Cut Penetration (mm)
- AUTOMATED DETECTION:** Roll Length and Outer Diameter are Automatically Detected

Rapid, user-friendly machine configuration.

3

SIMPLE UNLOAD

- CORE IS REUSABLE**
- SCRAP MATERIAL IS ENHANCED AND EASILY RECYCLABLE**

Streamlined removal of recovered core and material.

DIMENSION:
2644 (l) x 824 (w) - 1552 (h) mm
104.1 (l) x 32.4 (w) - 61.1 (h) in



✓ PLASTIC



✓ PAPER



✓ PAPER

CONTACT US

WhatsApp +39 339 208 2301

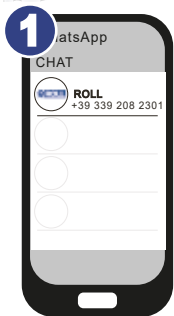

Find ROLL contact
(+39 339 208 2301)



Send us your pictures
Show us what you need,
the issue you are facing,
and the current situation.

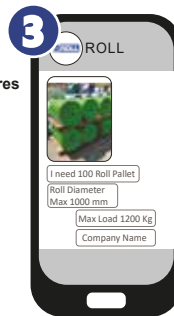

Send us your message
Please include:
Maximum roll diameter
Maximum roll weight
Indoor or outdoor use
Number of pieces required
Company name



www.roll-packaging.com

info@roll-packaging.com
+39 031 836 7000

Como - Italy